

THIS DRAWING IS UNPUBLISHED. RELEASED FOR PUBLICATION
 © COPYRIGHT BY TYCO ELECTRONICS CORPORATION. ALL RIGHTS RESERVED.

LOC	DIST	REVISIONS			
P	LTR	DESCRIPTION	DATE	DWN	APVD
AG	53	0	RELEASED	26JAN06	JDP JGH

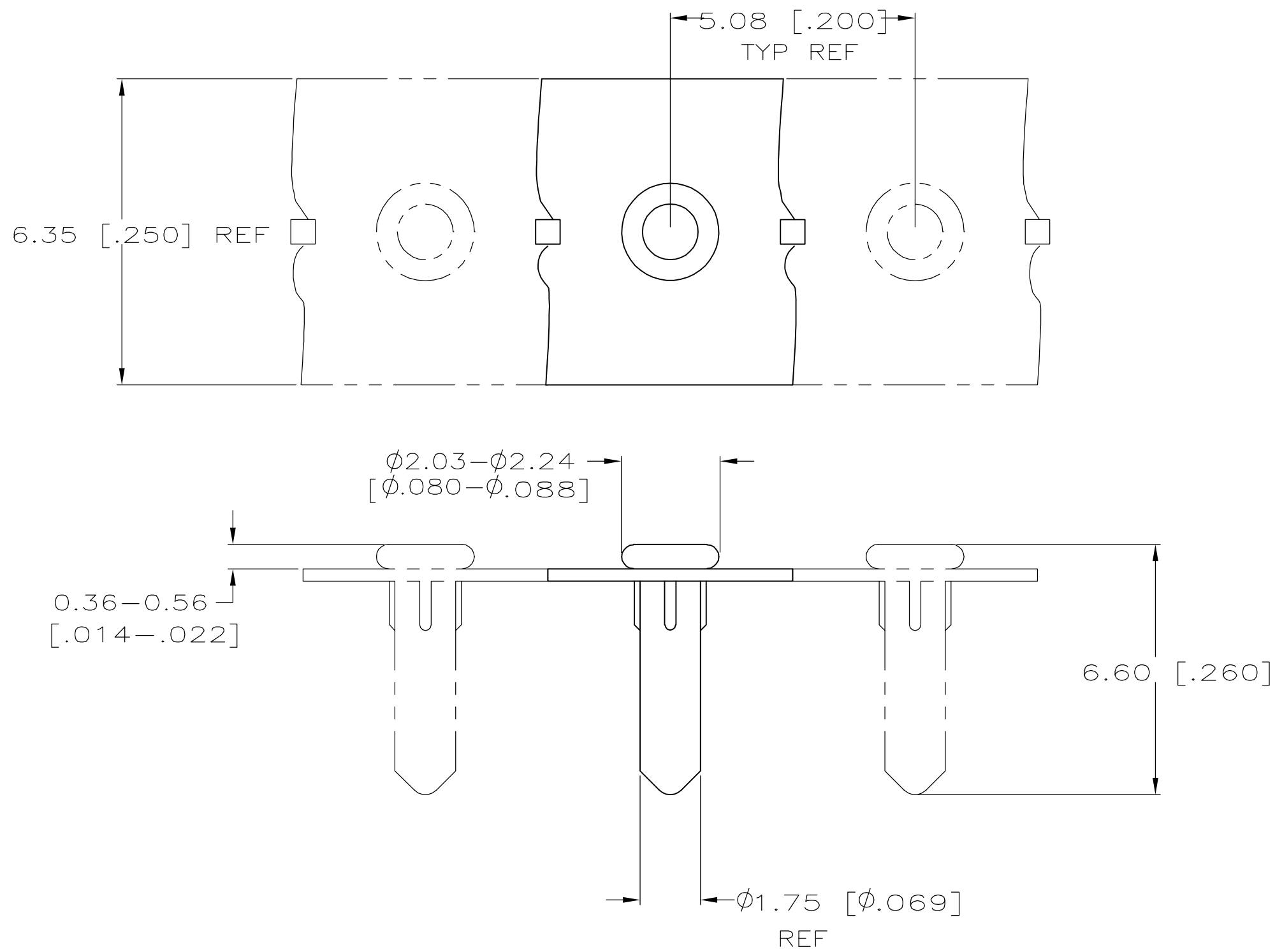

- 1 MATERIAL:
EYELET- COPPER PER ASTM B 152.
SPRING- BERYLLIUM-COPPER PER ASTM B 194.
- 2 TIN PLATE PER ASTM B 545, 0.00254 [.000100] MINIMUM THICKNESS.
- 3 GOLD PLATE PER ASTM B 488, 0.00076 [.000030] MINIMUM THICKNESS.
- 4 PACKAGE 50,000 PER REEL.
- 5 PACKAGE 10,000 PER REEL.
- 6 TO ENSURE 1/2 OZ MIN RETENTION, DO NOT EXCEED 0.50 [.002] DIFFERENCE IN PIN DIA WHEN CHANGING TO A SMALLER DIA PIN.
- 7 SHOULDER ON SOCKET PROVIDES RETENTION IN THE P.C. BOARD. THE RECOMMENDED HOLE DIAMETER IS φ1.75 [φ.069] MINIMUM, + 0.08 [.003] MAXIMUM PRIOR TO SOLDERING.

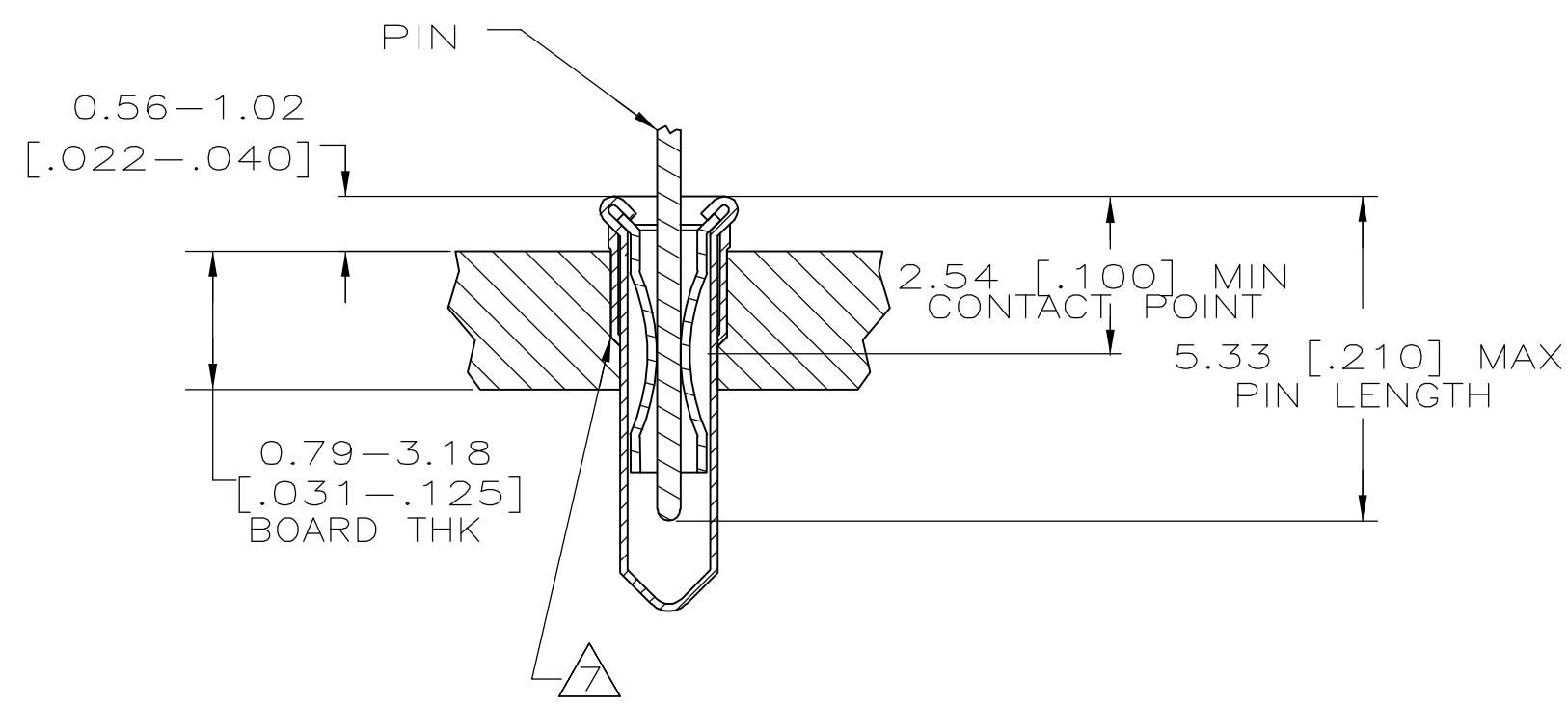

5	φ0.94-φ1.04 [φ.037-φ.041]	TIN 2	TIN 2	1-5645502-2
5	φ0.94-φ1.04 [φ.037-φ.041]	GOLD 3	TIN 2	1-5645502-1
4	φ0.94-φ1.04 [φ.037-φ.041]	GOLD 3	TIN 2	5645502-1
PACKAGING	PIN DIA 6	SPRING EYELET FINISH		PART NO

THIS DRAWING IS A CONTROLLED DOCUMENT.		DWN	J. POLIGNONE	26JAN06	 Tyco Electronics Corporation Harrisburg, PA 17105-3608							
DIMENSIONS: mm [INCHES]		CHK	J. HAVENER	26JAN06								
TOLERANCES UNLESS OTHERWISE SPECIFIED:		APVD	J. HAVENER	26JAN06								
0 PLC ± - 1 PLC ± - 2 PLC ± - 3 PLC ± 0.20[.008] 4 PLC ± - ANGLES ± - FINISH SEE TABLE		PRODUCT SPEC	108-14008			NAME	MINIATURE SPRING SOCKET ASSY SERIES 4					
MATERIAL	1	APPLICATION SPEC	114-26004		SIZE	A2	CAGE CODE	00779	DRAWING NO	C=5645502	RESTRICTED TO	-
CUSTOMER DRAWING					WEIGHT	-	SCALE	10:1	SHEET	1 of 1	REV	0

5645502